

THIS DRAWING IS UNPUBLISHED. RELEASED FOR PUBLICATION
 © COPYRIGHT BY TYCO ELECTRONICS CORPORATION. ALL RIGHTS RESERVED.

LOC	DIST	REVISIONS					
AJ	16	P	LTR	DESCRIPTION	DATE	DWN	APVD
		M1		REVISED PER ECO-05-009546	11OCT05	BM	JL

1. CRIMP TOOL: 69140-1
- △ WEIGHT: .412 OZ
3. SEE I.S. 1799-1

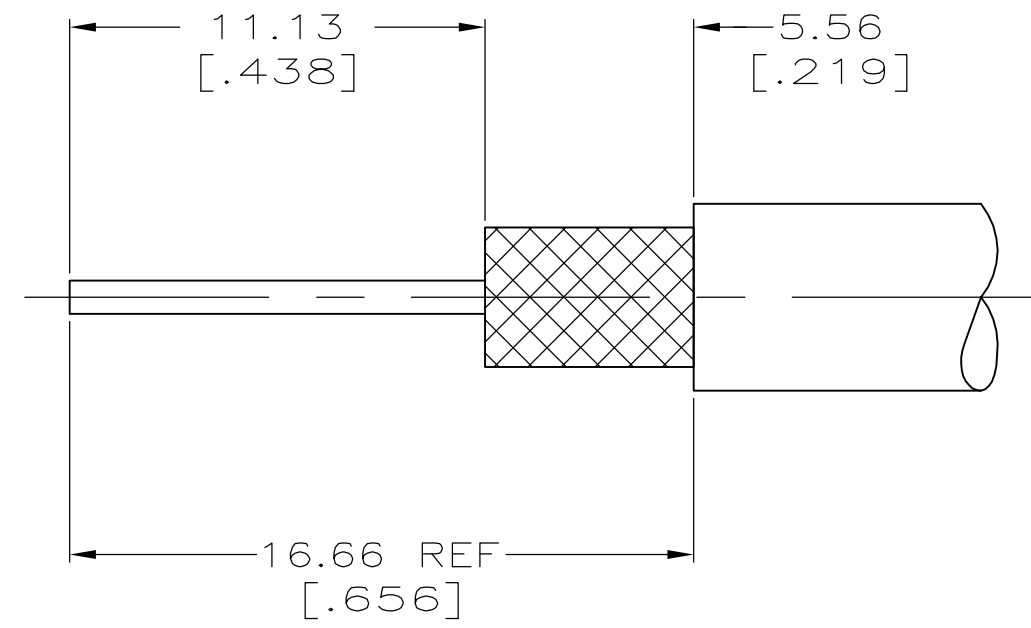

RECOMMENDED STRIP LENGTH

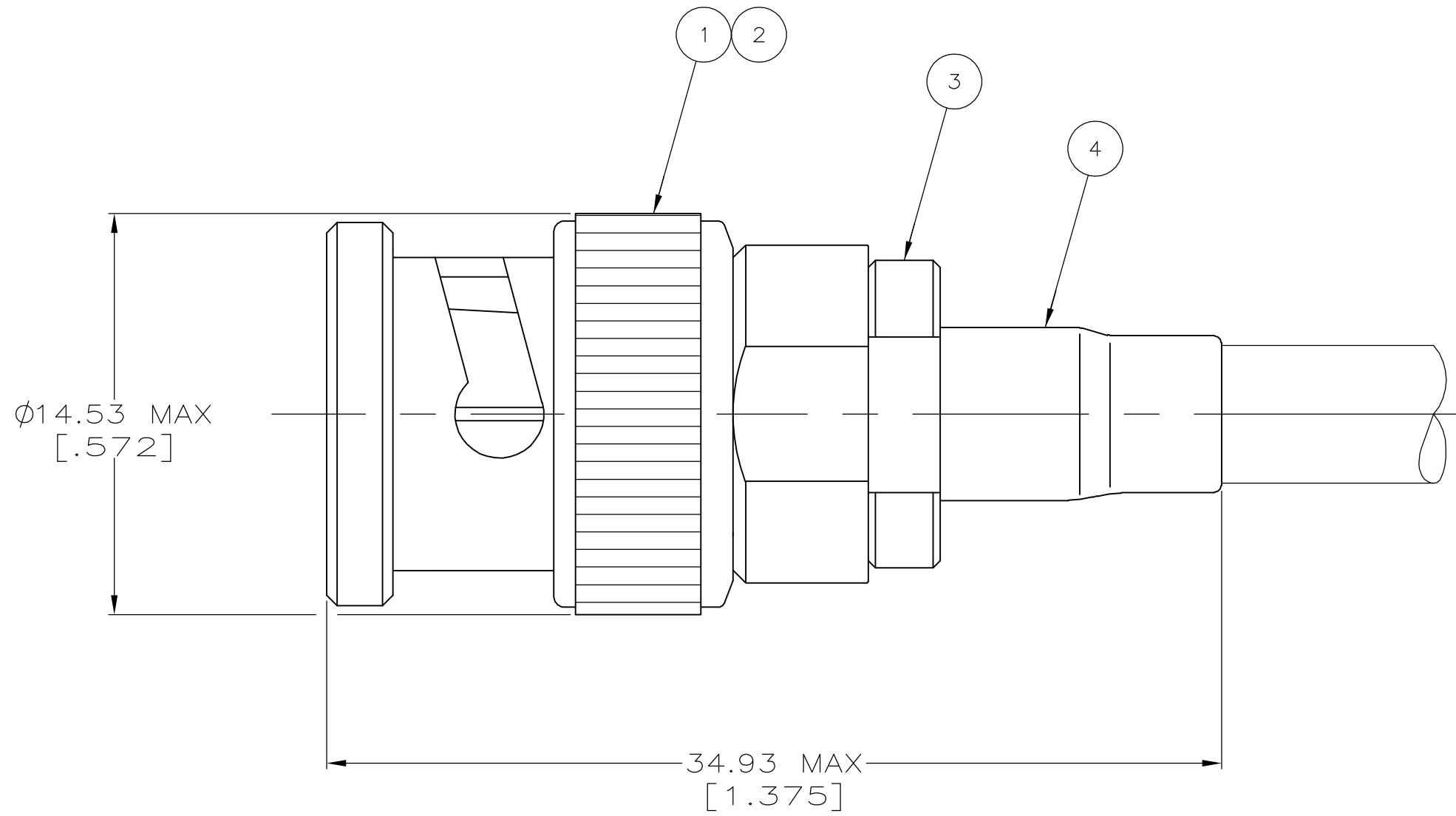

SUPSD BY: 2-5329082-1	RG-58/U,58A/U,58B/U & 58C/U	328663	50780	2-329106-1	9-329327-0	9-329082-0
SUPSD BY: 2-329444-2	-	-	-	-	-	2-329082-2
	RG-58/U,58A/U,58B/U & 58C/U	328663	50780	2-329106-1	329327	2-329082-1
CABLE SIZE	④ FERRULE QTY=1	③ CRIMP END ASSEMBLY QTY=1	② GASKET QTY=1	① PLUG ASSEMBLY QTY=1	PART NUMBER	

THIS DRAWING IS A CONTROLLED DOCUMENT.		DWN B. SCOTT 06-28-91	Tyco Electronics Corporation Harrisburg, PA 17105-3608	
DIMENSIONS: INCHES		CHK J. LIPPERT 7-30-91	NAME PLUG, SERIES BNC	
TOLERANCES UNLESS OTHERWISE SPECIFIED:		APVD -	PRODUCT SPEC -	
0 PLC ± -		APPLICATION SPEC -	SIZE A2	
1 PLC ± -		WEIGHT △	CAGE CODE 00779	DRAWING NO C=329082
2 PLC ± 0.41 [.016]		FINISH -	SCALE 5:1	SHEET 1 of 1
3 PLC ± -			REV M1	
4 PLC ± -				
ANGLES ± -				
MATERIAL -				
CUSTOMER DRAWING				